

# Stärker™ Specification

## ASEPTIC CONTAINER

555 US/gal CSC Container 2100 1.0 Bar with pillow plates  
Stärker™ Specification



**CORNERSTONE  
STAINLESS  
CONTAINERS**

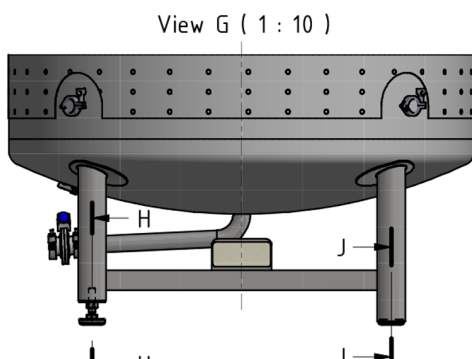
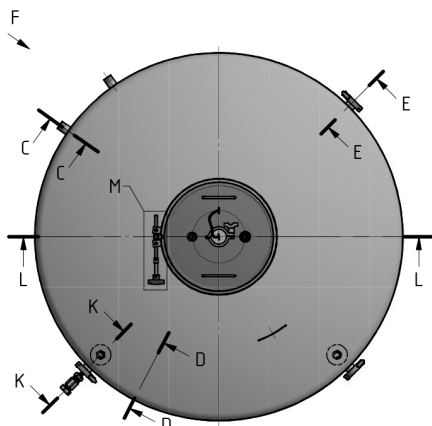
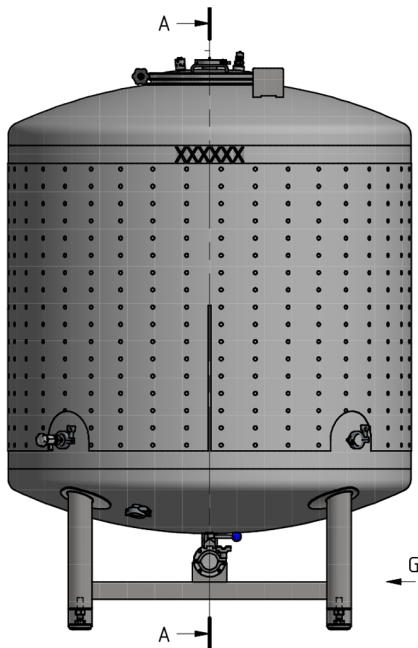

### MEASUREMENT

<b>Outside Diameter of container:</b>	1400mm/55.12inches
<b>Total Height:</b>	2013mm/79.24inches
<b>Outlet height:</b>	240 mm/9.45 inches
<b>Clearance:</b>	105 mm/4.13 inches
<b>Outlet Dimension:</b>	NW 2"
<b>Thicknesses of Sheets</b>	
<b>Dished Boiler Head:</b>	2mm/0.08inches
<b>Cylindrical Jacket:</b>	2mm/0.08inches
<b>Dished boiler bottom:</b>	2mm/0.08inches
<b>Outlet:</b>	2mm/0.08inches
<b>Struts:</b>	60x10mm/2.36x0.4inches

### MATERIAL

Container Parts which are in contact with product: 1.4301 (304 SS) 2B cold-rolled

**Other Parts:** 1.4301 (304 SS)

Acc. To PED 2014/68/EU, DIN EN 10028-1 and DIN EN 10028-7

### Surface Quality

Inner surface (mainside), which is in contact with product acc. To DIN EN 10021 and DIN EN 10163-2

### Gaskets

Manway Gasket DN 400: Silicone

Seal Collar of Butterfly Valve: Silicone

Screwing Gaskets: Perbunan

### Other Parts

Foot close with nylon cap (PA6)



### TYPE PLATE

<b>Volume :</b>	2100L
<b>Owner:</b>	Cornerstone Stainless Containers
<b>Max allowable pressure:</b>	3.0Bar for pillow plate/2.0Bar for inside
<b>Vacuum:</b>	-0.15bar/-0.15bar
<b>Test pressure:</b>	5.2bar/1.7bar
<b>Max Allowable temperature:</b>	-10 to 80 Celsius/-10 to 50 celsius
<b>Serial number:</b>	
<b>Container number:</b>	
<b>Year of fabrication:</b>	2019
<b>Tare:</b>	kg
<b>Marking-CE:</b>	

### EQUIPMENT

Manway lid dn400.

PRV dn12.

CO2 Valve dn12.

2" tri-clamp ferrule.

### CONTROLS

Eu pressure regulation certified

### WORKING CONDITIONS

Handling

4 sides pallet jack, 4 sides forklift

Not stackable



**Cornerstone Stainless Containers**  
**Address:** 23515 NE Novelty Hill Rd Suite  
B221-340 Redmond, WA 98053

**Call:** 425-686-4455

**Website:** [www.cornerstonestainlesscontainers.com](http://www.cornerstonestainlesscontainers.com)

**Email:** [sales@cornerstonestainlesscontainers.com](mailto:sales@cornerstonestainlesscontainers.com)